

العربية لخدمات الرافعات ش.م.م

ARABIAN CRANE

Your Partner in Lifting Business

SERVICES L.L.C.

- SALES
- SERVICE and SPARE PARTS
- CUSTOM-DESIGNED WIRELINES | E-LINE | SLICKLINE
- MOBILE CRANES • GEARS and TRANSMISSIONS

© Manitowoc | Grove | National Crane | Benchmark Wirelines

GROVE RT600E

product guide

-  40/45 tonnes
-  32 m
-  8.8 - 15.5 m
-  49.3 m



Rough Terrain Crane • Geländekran • Grue Tout-Terrain
Grúa Todo Terreno • Autogru Fuoristrada

 Manitowoc
Crane Group

www.arabiancrane.com

Email: sales@arabiancrane.com Tel: (968) 2459-3068 Fax: (968) 2459-3107

Contents • Inhalt • Contenu • Contenido • Contenuto

2

Specification	3
Technische Daten	4
Caractéristiques techniques	5
Características	6
Caratteristiche	7
Data • Daten • Caractéristiques • Datos • Dati	8
Dimensions • Abmessungen • Enncombrement • Dimensiones • Dimensioni	9
Load charts • Traglasten • Capacités de levage • Capacidades • Capacità	
Notes • Hinweise • Notes • Notas • Note	10
Working Range • Arbeitsbereiche • Diagramme de levage • Gama de trabajo • Area di lavoro	11
Telescopic Boom • Teleskopausleger • Flèche principale • Pluma telescópica • Braccio telescopico	12
Swingaway • Klappspitze • Extension treillis • Plumín • Falcone	16
Weight Reductions • Gewichte der Lastaufnahmemittel • Réductions de charge • Reducciones de peso • Riduzioni di peso	17
Notes • Hinweise • Notes • Notas • Note	
Symbols • Symbolerklärung • Glossaire des symboles • Glosario de simbolos • Glossario dei simboli	19

RT600E

GROVE

Specification

Superstructure

Boom

10.1 m to 32.0 m four section full power boom.
 Maximum tip height 34.1 m.

Boom elevation

1 cylinder with safety valve, boom angle from -2° to 78°.

Load moment and anti-two block system

Standard "Graphic Display" load moment and anti-two block system with audio-visual warning and control lever lockout. These systems provide electronic display of boom angle, length, radius, tip height, relative load moment, maximum permissible load, load indication and warning of impending two-block condition. The standard Work Area Definition System allows the operator to pre-select and define safe working areas. If the crane approaches the pre-set limits, audio-visual warnings aid the operator in avoiding job-site obstructions.

Cab

Galvanealed steel, acoustically treated, opening skylight with electric wiper and skylight sunscreen, deluxe seat with armrest-integrated crane controls, engine dependent hot water heater. Ergonomically arranged instrumentation and crane operating controls. Drive/steer controls.

Slewing

360° continuous rotation, planetary glide swing with foot applied brake. Spring applied hydraulically released parking brake and plunger type, 1 position mechanical house lock.

Counterweight

5,103 kg removable, plus slab in place of *auxiliary hoist.

Hydraulic system

3 main gear pumps combined capacity 391 l/min. Return line filter with bypass protection. Oil cooler and system pressure test ports. Tank capacity: 509 l.

Control system

Stepless control of all crane movements using single axis hydraulic pilot control levers with automatic reset to zero.

Hoist

Vane motor with planetary gear and automatic spring applied multi-disc brake. Grooved drum, hoist drum cable followers and electronic rotation indicator. 6x37 class hoist rope for 3.5:1 F.O.S.

* Optional equipment

8.8 m lattice swingaway (offsets 0°, 25°, 45°).
 8.8 - 15.5 m telescopic lattice swingaway (offsets 0°, 25°, 45°). Maximum tip height 49.3 m.
 35x7 class main hoist rope for 5:1 F.O.S.
 Auxiliary hoist package (includes auxiliary boom nose).
 360° mechanical slew lock operated from cab.
 Air conditioning.
 LMI light bar.

Carrier

Carrier frame

Special 2-axle carrier, all-welded torsion-resistant box type construction in high strength steel. Integral towing and tie down lugs.

Outriggers

4 hydraulically telescoping beams with 'inverted' jacks and 610 mm diameter outrigger pads. Independent horizontal and vertical movement control from the crane operator's cab. Three position setting. Sight level gauge. Maximum outrigger pad load: 29,278 kg.

Engine

Cummins B5.9TAA, 6 cylinder water cooled, turbocharged diesel. 129 kW (173 bhp) at 2500 rpm. Max. torque: 700 Nm at 1500 rpm. Fuel tank capacity: 227 l. Engine block heater.
 Engine emission: EUROMOT / EPA CARB (non road).

Transmission

Clark powershift 24000 series, 6 forward and 3 reverse speeds.

Drive/Steer

4 x 4 x 4

Axles

2 axles driven and steered. Front axle disconnect for 4 x 2 travel.

Suspension

Front axle rigid mounted to frame. Rear axle pivot mounted. Automatic oscillation lockouts permit oscillation only with boom centred over front.

Tyres

4 tyres, 23.5 x 25 - 20 PR earthmover type.

Steering

Front, full hydraulic steering wheel controlled. Separate steering of the rear axle for rear, crab and coordinated steering.

Brakes

Service brake: hydraulic dual circuit acting on all wheels.
 Parking brake: spring-applied, hydraulically released transmission mounted.

Electrical system

12 V (Two 12 V maintenance free batteries). Battery disconnect.

* Optional equipment.

CE Mark Conformance.
 4 tyres, 23.5 R25 Radials.
 Cross axle differential locks.
 Pump disconnect.
 Rear pintle hook.
 Aluminium decking.

3

RT600E

GROVE

*Further optional equipment upon request

Technische Daten

Kranoberwagen

Teleskopausleger

10,1 m bis 32,0 m vollhydraulisch teleskopierbarer 4-Stufen-Ausleger.
 Maximale Rollenhöhe 34,1 m.

Wippwerk

1 Hubzylinder mit Sicherheitsventil, Auslegerwinkel -2° bis 78°.

Lastmomentbegrenzer und Hubendabschaltesystem

Standard "Grafische Darstellung" Lastmomentbegrenzer und Hubendabschaltesystem mit audio-visueller Warneinrichtung und Bedienhebelabschaltung. Diese Systeme bieten eine elektronische Anzeige von Auslegerwinkel, Auslegerlänge, Ausladung, Rollenhöhe, relative Last, maximal zulässige Last, tatsächliche Last sowie eine Hubende-Warneinrichtung. Durch die Arbeitsbereich-begrenzung kann der Bediener sichere Arbeitsbereiche definieren. Fährt der Kran auf die Begrenzung des sicheren Arbeitsbereichs zu, wird der Bediener hörbar und visuell gewarnt. So können Kollisionen auf der Baustelle vorgebeugt werden.

Kabine

Verzinkte, schallgedämmte Stahlkabine, aufklappbares Dachfenster mit elektrischem Scheibenwischer und Sonnenschutz, Komfortsitz mit in die Armlenken integrierten Bedienhebeln, motorabhängige Heisswasserheizung. Ergonomisch angeordnete Bedienelemente und Kranbedienhebel. Fahr- und Lenkbedienung.

Drehwerk

360° rundum kontinuierlich schwenkbar, Planetenschwenkwerk mit Fusspedalschwenkbremse. Hydraulisch lösbare Federspeicher-Feststellbremse und mechanische, in 1 Stellung verriegelbare Bolzenverriegelung.

Gegengewicht

5103 kg abnehmbares Gegengewicht sowie ein Zusatzgewicht anstelle der *wahlweisen Hilfswinde.

Hydrauliksystem

3 Hauptzahnradpumpen mit einer Gesamtfördermenge von 391 l/Min. Filter mit Vollstrom-Überströmventil im Rücklauf. Ölkühler und Druckkontrollanschlüsse. Tankfassungsvermögen: 509 l.

Steuerung

Stufenlose Bedienung aller Kranbewegungen mittels hydraulischer Einachs-Bedienhebel mit automatischer Rückführung in die Nullstellung.

Hubwerk

Lamellenmotor mit Planetengetriebe und automatischer Federspeicher-Lamellenbremse. Gerillte Seiltrommel, Windenseilführung und elektronische Umdrehungsanzeige. Typ 6x37 Hubseil für 3.5:1 Sicherheitsfaktor.

* Zusatzausüstung

8,8 m Klappspitze (abwinklbar 0°, 25°, 45°).

8,8 - 15,5 m Teleskopklappspitze (abwinklbar 0°, 25°, 45°). Maximale Rollenhöhe 49,3 m.

Typ 35x7 Hubseil für 5:1 Sicherheitsfaktor.

Hilfswinde-Paket (einschl. Hilfsrollenkopf).

Von der Kabine aus bedienbare mechanische 360°-Schwenkwerkverriegelung.

Klimaanlage.

LMB (Lastmomentbegrenzer) Leuchtbalkenanzeige.

Kranunterwagen

Rahmen

2-Achsen-Spezial-Unterwagenrahmen, vollverschweißte, verwindungsfeste Kastenprofil-Konstruktion aus hochfestem Stahl. Integrierte Schlepp- und Verstauesen.

Abstützung

4 hydraulisch teleskopierbare Abstützbalken mit innengeführten Stützzylindern und 610 mm (Durchmesser) Abstützteilern. Unabhängige Bedienung der horizontalen und vertikalen Bewegungen von der Krankabine aus. Teil-Auslage in 3 Stellungen verbolzbar. Nivellierlibelle. Maximale Stütztellerlast: 29278 Kg.

Motor

Cummins B5.9TAA, wassergekühlter 6-Zylinder-Turbodieselmotor. 129 KW (173 PS) bei 2500 U/Min. Max. Drehmoment: 700 Nm bei 1500 U/Min. Fassungsvermögen Treibstofftank: 227 l. Motorblock-Heizung. Abgasemission: EUROMOT / EPA / CARB (nicht Strasse).

Getriebe

Clarc Powershiftautomatikgetriebe Serie 24000, 6 Vorwärtsgänge und 3 Rückwärtsgänge.

Antrieb/Lenkung

4 x 4 x 4

Achsen

Zwei Achsen angetrieben und lenkbar. Vorderachse für 4 x 2 Fahrt abschaltbar.

Federung

Vorderachse starr am Unterwagenrahmen montiert. Hinterachse als Pendelachse montiert. Die automatische Federungsverriegelung entriegelt die Federung nur dann, wenn der Ausleger nach vorn eingemittelt ist.

Bereifung

4 Reifen, 23.5 x 25 - 20 PR Radladerreifen.

Lenkung

Vorn vollhydraulische Lenkung mittels Lenkrad. Separate Lenkung der Hinterachse für hintere Lenkung, Hundegang oder koordinierte Lenkung.

Bremsen

Betriebsbremse: Zweikreis-Hydraulik-Bremssystem, auf alle Räder wirkend. Feststellbremse: Hydraulisch lösbare Federspeicher-Feststellbremse am Getriebe montiert.

Elektrische Anlage

12 V (Zwei 12 V wartungsfreie Batterien). Batterietrennung.

* Zusatzausrüstung

CE Zertifikat.

23.5 R25 Radialreifen.

Querdifferentialsperren.

Pumpenabschaltung.

Abschlepphaken.

Aluminiumdeck.

4

RT600E

GROVE

*Weitere Zusatzausrüstungen auf Anfrage

Caractéristiques techniques

Superstructure

Flèche

Flèche quatre éléments de 10,1 m à 32,0 m à télescopage hydraulique. Hauteur max. de tête de flèche 34,1 m.

Relevage

1 vérin avec clapet anti-retour, angle de flèche de -2° à + 78°.

Contrôleur d'état de charge et dispositif de fin de course haute

Contrôleur d'état de charge à affichage graphique et dispositif de fin de course haute avec alarme sonore et visuelle et dispositif de coupure des mouvements. Ces dispositifs électroniques affichent les indications d'angle et de longueur de flèche, de portée, de hauteur de tête de flèche, de moment relatif, de charge maximum admissible, de charge levée et d'approche de bloc à bloc. Le dispositif de définition de domaine de travail, monté de série, permet à l'utilisateur de définir des limites de zone de travail. Si la grue approche ces limites, des alarmes sonores et visuelles préviennent l'utilisateur.

Cabine

Cabine en tôle galvanisée, insonorisée, avec baie de toit ouvrante, essuie glace électrique et rideau pare-soleil, siège capitonné avec commandes de grue montées sur les accoudoirs, chauffage à eau chaude alimenté par le moteur thermique. Disposition ergonomique de l'instrumentation et des commandes de grue. Commandes de conduite pour le déplacement et la direction du porteur.

Orientation

Orientation continue sur 360° avec réducteur à planétaires « glide swing » et frein au pied. Frein d'immobilisation à serrage par ressorts et desserrage hydraulique. Axe de verrouillage d'orientation sur une position.

Contrepoids

Contrepoids de 5.103 kg déposable plus plaque amovible en lieu de treuil auxiliaire.

Circuit hydraulique

3 pompes principales à engrenages ayant un débit total de 391 l/min. Filtration sur circuit retour avec circuit « by-pass ». Refroidisseur d'huile hydraulique et prises de pressions. Capacité du réservoir : 509 l.

Commandes de grue

Commandes progressives par leviers simple axe et retour au neutre automatique.

Treuil

Moteur à palettes avec réducteur à planétaires et frein automatique à serrage par ressorts et desserrage automatique. Treuil rainuré, rouleau presse câble et indicateur électronique de rotation du tambour. Câble de levage classe 6x37 donnant un coefficient de sécurité de 3.5:1

* Equipements optionnels

Extension à repliage latéral de 8,8 m (inclinaison à 0°, 25° et 45°).
 Extension à repliage latéral et télescopique de 8,8 à 15,5 m (inclinaison à 0°, 25° et 45°). Hauteur max. de tête de flèche 49,3 m.
 Câble de levage (classe 35x7) donnant un coefficient de sécurité de 5:1.
 Equipement treuil auxiliaire (incluant la tête de flèche auxiliaire).
 Dispositif de verrouillage mécanique sur 360°, commandé depuis la cabine.
 Climatisation.
 Barre de répétition d'affichage de moment C.E.C.

Porteur

Châssis porteur

Châssis caissonné, mécanosoudé, spécifique, à 2 essieux, en tôles d'acier à haute limite élastique, avec oreilles de remorquage et d'arrimage intégrées.

Calage

4 poutres à télescopage hydraulique avec vérins verticaux en position « inversée » et semelles d'appui de 610 mm de diamètre. Commande indépendante des mouvements de sortie de poutres et de vérins depuis le poste de pilotage. Trois configurations de calage sont autorisées, 0 - 50 et 100%. Niveau à bulle. Charge maximum sur les appuis: 29.278 kg.

Moteur

Moteur Diesel Cummins B5.9TAA, 6 cylindres, à refroidissement liquide et dispositifs de suralimentation. 129 kW (173 CV) à 2500 tr/min. Couple max.: 700 Nm à 1500 tr/min. Capacité du réservoir de carburant : 227 l. Emissions de gaz polluants: EUROMOT / EPA CARB (normes chantier). Réchauffage du bloc-moteur.

Boîte de vitesses

Boîte de vitesses Clark 24000, 6 rapports de marche avant et 3 rapports de marche arrière.

Direction/Déplacement

4 x 4 x 4

Ponts

2 ponts moto-directeurs. Pont avant débrayable pour déplacements sur route.

Suspension

Pont avant rigide fixé au châssis. Pont arrière articulé. Le dispositif automatique de verrouillage d'articulation libère la suspension lorsque la flèche est centrée sur l'avant.

Pneumatiques

4 pneumatiques 23.5 x 25 - 20 PR de type chantier.

Direction

Direction avant hydraulique commandée par volant. Direction indépendante pour les roues arrière donnant les configurations : direction arrière, marche en crabe et direction coordonnée.

Freins

Frein de service: double circuit hydraulique agissant sur toutes les roues. Frein de stationnement: à serrage par ressorts et desserrage hydraulique agissant sur la transmission.

Circuit électrique

12 V (Deux batteries 12 V sans entretien). Coupe batteries.

* Equipements optionnels

Conformité CE.
 4 pneus, 23.5 R25 radiaux.
 Blocages de différentiels inter-roues.
 Débrayage de pompe.
 Crochet de remorquage.
 Platelage en aluminium.

5

RT600E

GROVE

Características

Superestructura

Pluma

De 10,1 m. hasta 32,0 m. en 4 tramos de telescopaje totalmente hidráulico. Altura máxima en punta 34,1 m.

Elevación de pluma

Un cilindro con válvula de seguridad. Angulo de pluma desde -2° hasta 78°.

Sistema Indicador del Momento de Carga y de Final de Carrera del Gancho

La Pantalla Gráfica estandar. Indicador del momento de carga y de final de carrera del gancho con alarma audiovisual y bloqueo automático de las palancas de control. Estos sistemas proporcionan información en la pantalla del ángulo de pluma, longitud, radios, altura, momento de carga relativo, carga máxima permitida, indicador de carga y alarma de final de carrera del gancho. El sistema estandar de Area Definida de Trabajo permite al operador preseleccionar y definir las zonas seguras de trabajo. Si la grúa se acerca a los límites preseleccionados, la alarma audio-visual avisa al operario para evitar obstrucciones en el lugar de trabajo.

Cabina

De acero galvanizado, tratada acústicamente, ventana superior abatible con limpia-parabrisas eléctrico y persiana parasol en techo, asiento de lujo con controles de operación de la grúa e instrumentación ergonómicamente situadas, calefacción por agua caliente del motor. Controles de traslación/dirección.

Giro

Continuo a 360°, giro deslizante con planetarios y freno actuado por pedal. Freno de aparcamiento aplicado por muelle con desconexión hidráulica y pistón, bloqueo mecánico en 1 posición.

Contrapeso

De 5.103 kg. desmontable, más una placa en lugar del *cabrestante auxiliar.

Sistema hidráulico

Tres bombas principales de engranaje con una capacidad combinada de 391 litros/minuto. Filtro en la línea de retorno con protección by-pass. Radiador de refrigeración de aceite y sistema de comprobación de presión. Capacidad del depósito 509 litros.

Sistema de Control

Controles continuos de todos los movimientos de la grúa, usando palancas de control con retorno automático a cero.

Cabrestante

Con motor de paletas, engranaje planetario y freno automático multidisco aplicado por muelle. Tambor acanalado, ordenador de cable en el tambor e indicador de dirección. Cable del cabrestante con un factor de seguridad de 3.5 a 1.

* Equipos Opcionales

Plumín de celosía de 8,8 m. fijo, plegable en un lateral de la pluma (angulable 0°, 25° y 45°).

Plumín telescópico de 8,8 - 15,5 m. plegable en un lateral de la pluma (angulable 0°, 25° y 45°). Altura máxima en punta 49,3 m.

Cable (35x7) con un factor de seguridad de 5 a 1.

Conjunto de cabrestante auxiliar (incluye la cabeza auxiliar tipo nariz).

Bloqueo mecánico de giro en los 360° accionado desde la cabina.

Aire acondicionado.

Tubo de iluminación del Indicador de cargas.

Chasis

Bastidor

Chasis especial de dos ejes de construcción soldada tipo cajón resistente a la torsión, en acero de alta resistencia. Gancho de arrastre y orejetas de amarre.

Estabilizadores

4 vigas telescópicas hidráulicas con cilindros verticales invertidos y placas de apoyo cuadradas de 610 mm. de superficie. Controles independientes para los movimientos horizontales y verticales desde la cabina del operador. Tres posiciones de aplicación. Manómetro indicador de nivel. Carga máxima en cada placa de apoyo 29.278 kg.

Motor

Diesel Cummins B5.9TAA, 6 cilindros, refrigerado por agua, turbo-alimentado, 129 Kw (173 bhp) a 2.500 rpm. Par máximo: 700 Nm a 1.500 rpm. Depósito de combustible: 227 litros. Calentamiento del bloque motor. Emisión de gases: EUROMOT/EPA/CARB (non-road).

Transmisión

Clark powershift serie 24000, 6 velocidades adelante y 3 atrás.

Tracción/Dirección

4 x 4 x 4

Ejes

2 ejes motrices y directrices. Eje delantero desconectable para desplazamiento 4x2.

Suspensión

Montaje rígido al bastidor en el eje delantero. En el eje trasero pivotante. Bloqueo automático de oscilación únicamente con la pluma centrada por la parte frontal.

Neumáticos

4 de 23.5 x 25-20 lonas, tipo movimiento de tierras.

Dirección

Delantera, completamente hidráulica con control por volante. Control independiente del eje trasero para dirección trasera, tipo cangrejo y coordinada.

Frenos

De Servicio: Hidráulicos de doble circuito, actuando sobre todas las ruedas.

De Aparcamiento: Aplicado por muelle con desconexión hidráulica sobre la transmisión.

Sistema eléctrico

12 V (dos baterías de 12 V sin mantenimiento). Desconector de baterías.

* Equipos Opcionales

Complimiento de las Directivas Comunitarias.

4 neumáticos 23.5 R25 radiales.

Bloqueo cruzado del diferencial.

Desconector de la bomba.

Gancho de arrastre trasero.

Carrocería de aluminio.

6

RT600E

GROVE

*Otros opcionales a petición

Caratteristiche

Torretta

Braccio

Da 10,1 a 32 m, 4 sezioni con sfilamento completamente idraulico.
 Altezza massima: 34,1 m.

Sollevamento Braccio

Un cilindro idraulico con valvola di blocco, angolo braccio da -2° a +78°.

Limitatore di carico e blocco dei movimenti

Display grafico standard per limitazione di carico e blocco dei movimenti con allarme visivo e sonoro e controllo dell'esclusione delle leve. Questo sistema è provvisto di display elettronico riportante l'angolo e la lunghezza del braccio, il raggio di lavoro, l'altezza di lavoro, il momento, il peso ammissibile, il peso attuale. Allarme di blocco sui movimenti. Lo standard Work Area Definition System permette all'operatore di preselezionare e definire le aree di lavoro sicure. Se l'autogrù si avvicina ai limiti preselezionati, l'allarme visivo e sonoro aiuta l'operatore a evitare difficoltà sul lavoro.

Cabina

Costruita in acciaio galvanizzato, insonorizzata, vetro superiore apribile con tergicristallo elettrico e tendina parasole, comodo sedile con comandi integrati nei braccioli, strumentazione ergonomica, comandi sterzo e guida. Riscaldamento ad acqua dipendente dal motore.

Rotazione

Rotazione continua a 360° con riduttore a planetari con freno a pedale. Freno di parcheggio rilasciato idraulicamente tramite molle e bloccaggio con perno meccanico in una posizione.

Contrappeso

Da 5.103 kg smontabile, più una piastra al posto del secondo argano.

Impianto idraulico

3 pompe principali a ingranaggi con capacità totale di 391 l/min. Filtro sul ritorno con protezione by-pass. Raffreddamento olio idraulico con controllo termostatico e collegamenti per controllo pressione del sistema. Capacità del serbatoio: 509 l.

Comandi

Tutti i movimenti della gru sono controllati continuamente con leve di comando a regolazione idraulica per ogni manovra con richiamo automatico al punto zero.

Argano

Motore a palette con riduttore a planetari e freno automatico a dischi. Tamburo scanalato, guide per cavo tamburo argano e indicatore di rotazione elettronico. Fune classe 6x37 per fattore di sicurezza 3,5:1. Indicatore di rotazione argano.

*Accessori opzionali

8,8 m di jib ripiegabile (inclinabile da 0°, 25° a 45°)
 8,8 m-15,5 m di jib telescopico ripiegabile (inclinabile da 0°, 25 a 45°).
 Altezza massima: 49,3 m.
 Fune classe 35x7 per fattore di sicurezza 5:1.
 Equipaggiamento con secondo argano (include la testa del braccio ausiliaria)
 Bloccaggio meccanico della rotazione a 360° controllato dalla cabina dell'autogrù.
 Aria condizionata
 Barre luminose LMC

Carro

Telaio

Carro speciale, 2 assi, costruzione in acciaio scatorato ad alta resistenza, resistente alla torsione. Occhioni di traino integrati.

Stabilizzatori

4 travi telescopiche orizzontali idrauliche con cilindri verticali e piattelli d'appoggio con una superficie del piatto di 610mm. Comandi indipendenti dei movimenti orizzontali dalla cabina del carro. Tre configurazioni di bloccaggio. Indicatore livello a bolla. Carico massimo piattelli stabilizzatori: 29278 kg

Motore

Cummins B5.9TAA, 6 cilindri, turbo 129Kw (173 bhp) a 2500 giri al minuto. Coppia max: 700 Nm a 1500 giri al minuto. Capacità del serbatoio: 227 l. Emissioni gassose allo scarico: EUROMOT/EPA CARB (no su strada). Riscaldamento del blocco motore.

Cambio

Clark automatico 24000, 6 marce avanti più 3 retromarcia.

Trazione/Sterzo

4 x 4 x 4

Assali

2 assi sterzanti e di trazione. Possibilità di non azionare l'asse anteriore per percorsi 4x2.

Sospensioni

Asse anteriore montato fisso sul telaio del carro. Asse posteriore articolato. Il dispositivo automatico di bloccaggio sospensioni sblocca la sospensione solo se il braccio è centrato in avanti.

Pneumatici

4 pneumatici, 23,5 x 25-20 PR tipo movimento terra.

Sterzo

Sterzo anteriore completamente idraulico tramite il volante. Sterzo separato dell'asse posteriore per sterzata posteriore, a granchio e combinata.

Freni

Freno di servizio: idraulico a doppio circuito, agente su tutte le ruote. Freno di parcheggio: con molle precaricate a comando idraulico montato sul cambio.

Impianto elettrico

12V (2 batterie) da 12V senza manutenzione. Disinserimento batteria.

*Equipaggiamenti opzionali

Certificato CE.
 4 pneumatici, 23,5 R25.
 Differenziale autobloccante.
 Pompa scollegabile.
 Gancio per rimorchio.
 Rivestimento in alluminio.

7

RT600E

GROVE

*Altri a richiesta.

Data • Daten • Caractéristiques • Datos • Dati

8



Axle Achse Essieu Eje Asse	1	2	Total weight Gesamtgewicht Poids total Peso total Peso totale
t	14.0	16.6	30.6



Lifting Capacity Traglast Force de levage Capacidad de elevación Capacità di sollevamento	Sheaves Rollen Poules Poleas Carrucole	Parts of line Stränge Brins Ramales de cable Numero di funi	Weight Gewicht Poids Peso Peso
45 t	3	2 - 6	454 kg
35 t	3	2 - 6	363 kg
7.5 t	H/B (swivel)	1	167 kg



+

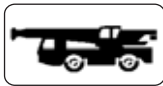

	1	2	3	4	5	6	R1	R2	R3	
km/h	3	6	9	16	23	39	3	9	23	70%
	23.5 x 25									



+



	Infinitely variable stufenlos progressivement variable Infinitamente variable Infinitamente variabile	Rope Seil Câble Cable Fune	Max. permissible line pull Maximal zulässige Seilzugkraft Effort maximum autorisé sur brin simple Potencia máxima admisible por ramal Tiro massimo ammissibile della fune
	0 - 179 m/min single line für einfachen Strang brin simple ramal simple tiro a fune singola	19 mm/137 m (6 x 37 class) ▲ 19 mm/137 m (35 x 7 class)	7620 kg 7620 kg
	0 - 179 m/min single line für einfachen Strang brin simple ramal simple tiro a fune singola	19 mm/137 m (35 x 7 class)	7620 kg
	0 - 2.5 min ⁻¹		
	20° to 70° approx. 20 s ca. 20 s env. 20 s aproximadamente 20 s circa 20 s		
	10.1 m to 32.0 m approx. 44 s ca. 44 s env. 44 s aproximadamente 44 s circa 44 s		

RT600E

GROVE

▲ Required for 5:1 Rope F.O. S., Gefordert bei 5:1 Sicherheitsfaktor am Hubseil, Nécessaire pour coefficient de sécurité de 5:1 du câble de levage, Necesario para el factor de seguridad de 5 a 1 del cable cabrestante, Necessario per un coefficiente di sicurezza 5:1 della fune di sollevamento.

Dimensions • Abmessungen • Encombrement • Dimensiones • Dimensioni

9

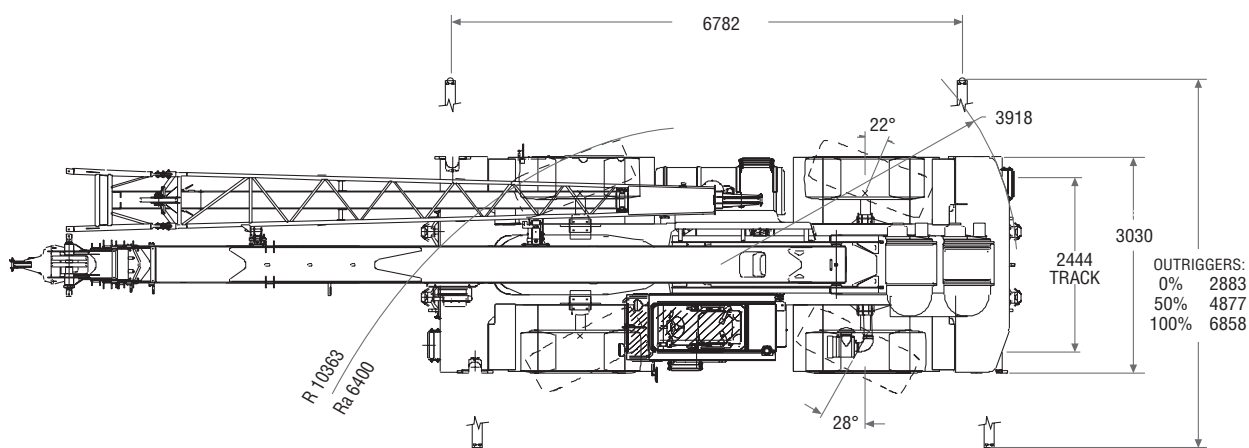
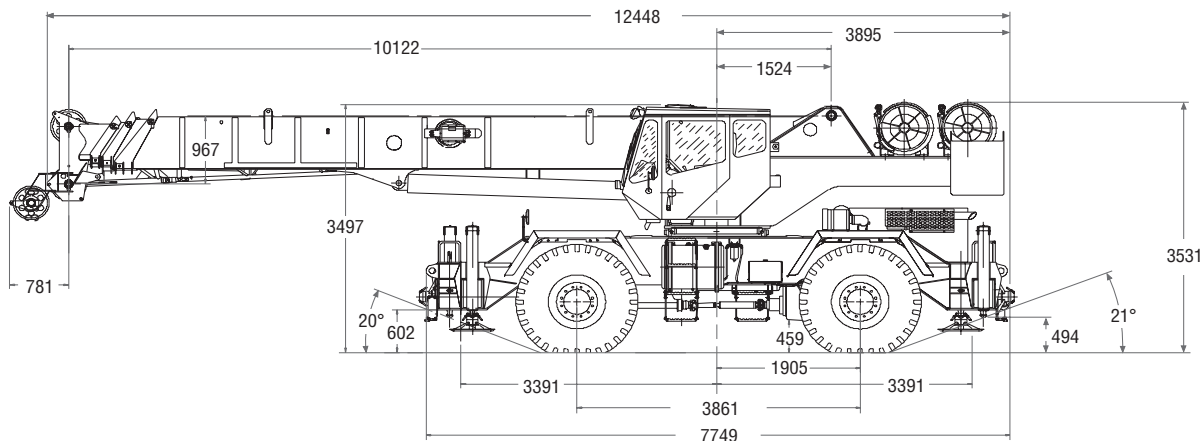

Ra = Radius all wheels steered
 Radius allradgelenkt
 Rayon toutes les roues directrices
 Radio de giro con todas las ruedas giradas
 Raggio di curva con tutte le ruote sterzate

RT600E

GROVE

Load charts • Traglasten • Capacités de levage • Capacidades • Capacità

Notes • Hinweise • Notes • Notas • Note

Lifting capacities according to DIN/ISO • 85%

Warning: THIS CHART IS ONLY A GUIDE. The Notes below are for illustration only and should not be relied upon to operate the crane. The individual crane's load chart, operating instructions and other instruction plates must be read and understood prior to operating the crane.

DIN/ISO: The mechanical strength complies with DIN 15018, part 3. Tipping conditions are governed by DIN 15019, part 2 and ISO 4305 standards.

They also take into account the requirements of prEN 13000: 2003 and therefore comply with the requirements of the EU machinery directive.

85%: Capacities are in accordance with SAE J1063 and do not exceed 85% of the tipping load (SAE J1289 for outriggers 50% and 0% extended) as determined by SAE J765.

- Capacities given do not include the weight of hookblocks, slings, auxiliary lifting equipment and load handling devices. Their weights MUST be added to the load to be lifted. When more than minimum required reeving is used, the additional rope weight shall be considered part of the load.
- All capacities are for crane on firm, level surface. It may be necessary to have structural supports under the outrigger floats or tyres to spread the load to a larger bearing surface.
- When either boom length or radius or both are between values listed, the smallest load shown at either the next larger radius or boom length shall be used.
- For outrigger operation, ALL outriggers shall be fully extended with tyres raised free of ground before raising the boom or lifting loads.
- Tyres shall be inflated to the recommended pressure before lifting on rubber.

Traglasten entsprechen DIN/ISO • 85%

WARNUNG: DIESE TABELLE IST LEDIGLICHE EINE RICHTLINIE. Die Hinweise dienen als Erklärung und sind für die Kranbedienung nicht maßgebend. Vor Inbetriebnahme des Kranes sind Traglasttabellen, Bedienungsanleitung und andere Vorschriften eingehend zu studieren.

DIN/ISO: Der Festigkeitsberechnung liegen die DIN 15018 Teil 3 zugrunde. Die Traglasten im Standsicherheitsbereich entsprechen DIN 15019 Teil 2 und ISO 4305. Sie berücksichtigen außerdem die Forderungen von prEN 13000: 2003 und entsprechen damit den Anforderungen der Maschinenrichtlinie.

85%: Tragkraftwerte entsprechen SAE J1063 und überschreiten nicht 85 % der Kipplast (SAE J1289 bei halb- bzw. ganz ausgefahrener Abstützung) gemäß Richtlinien SAE J 765.

- Das Gewicht der Hakenflaschen und aller Anschlagmittel muß zu der Last hinzugerechnet werden. Beim Einscheren mit erhöhten Werten ist das zusätzliche Seilgewicht als Teil der Last zu betrachten.
- Alle Werte gelten für den Kran auf festem, ebenem Untergrund. Eventuell müssen die Stützsteller oder Reifen unterlegt werden, um die Last über eine größere Abstützfläche zu verteilen.
- Wenn Auslegerlänge oder Radius oder beide Werte zwischen den aufgeführten Werten liegen, ist die geringere der Traglasten zu wählen, die für den die nächstgrößere Ausladung oder die nächste bzw. anschließende Auslegerlänge genannt sind.
- In abgestütztem Zustand müssen ALLE Stützen komplette ausgefahren sein. Die Reifen dürfen den Boden nicht berühren. Erst danach dürfen Lasten oder der Ausleger angehoben werden.
- Bevor frei auf Rädern gearbeitet wird, müssen, die Reifen mit dem vorgeschriebenen Druck aufgefüllt werden.

Capacités de levage selon DIN/ISO • 85%

ATTENTION: CE TABLEAU N'EST QU'UN GUIDE. Les notes ci-dessous sont données à titre d'exemple et ne devront pas être utilisées pour faire fonctionner la grue. Toute la documentation concernant chaque type de grue: tableau des charges, instructions de fonctionnement et toutes autres plaques d'instructions devront être lues et comprises avant de manoeuvrer la grue.

DIN/ISO: Les limites du basculement sont conformes à la norme DIN 15019 section 2 et ISO 4305. Elles tiennent également compte des paramètres établis pour le projet de norme Européenne prEN 13000: 2003 et de ce fait satisfont les exigences de la Directive Européenne Machines.

85%: Les capacités de levage sont conformes à la norme SAE J1063 et ne dépassent pas 85% de la charge de basculement (SAE J1289 pour les poutres de calage déployées à 50% et 0%) tel que cela est prescrit par la norme SAE J765.

- Les charges mentionnées dans les tableaux ne comprennent pas le poids des mouffes, des élingues et autres accessoires de levage qui doit être additionné à celui de la charge levée. Lorsque le mouffage est supérieur au minimum requis le poids de l'excédent de câble doit être additionné à celui de la charge.
- Les capacités sont données sur sol ferme et de niveau. Il peut être nécessaire d'utiliser des bastinges ou des accessoires similaires afin de répartir la charge transmise au sol par les roues ou les patins de calage.
- Lorsque la longueur de flèche ou la portée ne correspond pas aux valeurs mentionnées dans les tableaux, il convient de se référer à la valeur inférieure mentionnée pour la portée ou la longueur de flèche immédiatement supérieure.
- Pour utilisation machine calée, les poutres de calage doivent être totalement télescopées et les roues décollées du sol avant de relever la flèche ou de lever des charges.
- Les pneumatiques devront être gonflés aux pressions préconisées avant tout levage en libre.

Capacidades de elevación de acuerdo con DIN/ISO • 85%

AVISO: ESTA TABLA ES SOLO UNA ORIENTACION. Las notas que aparecen al final de la misma solo sirven de ilustración y no deben ser tomadas como instrucciones para operar la grúa. La tabla de cargas, las instrucciones de operación y otras placas ilustrativas de cada grúa deben ser leídas y correctamente interpretadas antes de operar la grúa.

DIN/ISO: Los analisis de resistencia están basados en las normas DIN 15018. Apartados 3. Las condiciones de vuelco están reguladas por las normas

DIN 15019 apartado 2 y ISO 4305. Tienen tambien cuenta de las exigencias establecidas por prEN 13000: 2003 y asi cumplen con los requerimientos de las Directivas de Maquinaria UE.

85%: Capacidades de acuerdo con las Normas SAE J1063 y no exceden del 85% del momento de vuelco (Normas SAE J1289 para las cargas sobre estabilizadores extendidos al 50% o sin extender 0%) como fijan las normas SAE J765.

- Las cargas indicadas no incluyen el peso de los ganchos, eslingas, equipos auxiliares y aparejos de elevación. Sus pesos DEBEN ser añadidos al de la carga a elevar. Cuando se utilice un número de ramales de cable superior al necesario, el peso adicional del cable debe ser considerado como parte de la carga.
- Todas las capacidades corresponden a la grúa situada sobre terreno firme nivelado y uniforme. La naturaleza del terreno puede hacer necesario colocar, bajo los apoyos de los estabilizadores o bajo los neumáticos, elementos estructurales que repartan la carga sobre una mayor superficie de apoyo.
- Cuando se trabaje con longitudes de pluma o rádios, intermedios entre los valores reflejados en las tablas, se considerará la carga inmediata inferior indicada en el radio o longitud de pluma inmediato superior.
- Para trabajos sobre estabilizadores, TODOS los estabilizadores estarán totalmente extendidos y los neumáticos sin tocar el suelo antes de elevar pluma o izar cargas.
- Los neumáticos deberán estar inflados a la presión recomendada antes de elevar cargas sobre neumáticos.

Capacità di sollevamento in accordo con DIN/ISO • 85%

ATTENZIONE: QUESTA TABELLA E' SOLO UNA GUIDA. Le note qui sotto riportate sono date a titolo d'esempio e non devono essere utilizzate per far funzionare la gru. La tabella di carico, le istruzioni d'uso ed ogni altro foglio illustrativo devono essere letti e compresi prima di manovrare la gru.

DIN/ISO: il calcolo di resistenza è basato sulle norme DIN 15018, parte 3. Le condizioni di ribaltamento sono regolate dalle norme DIN 15019 parte 2 e ISO 4305. Esse tengono conto anche dei parametri stabiliti da prEN13000: 2003 e quindi soddisfano le richieste della Direttiva Macchine Europea.

85%: Le capacità di sollevamento sono conformi alla norma SAE J1063 e non superano l'85% del carico di ribaltamento (SAE J1289 per gli stabilizzatori estesi al 50% e 0%) come prescritto dalla norma SAE J765.

- I carichi indicati nelle tavole non comprendono il peso dei ganci, dei tiranti, e di nessun altro accessorio di sollevamento che deve essere aggiunto a quello del carico sollevato. Quando il numero di funi è superiore al minimo richiesto il peso addizionale della fune deve essere aggiunto a quello del carico.
- Tutte le capacità si intendono per la gru situata su un terreno compatto livellato e uniforme. Potrebbe rendersi necessario utilizzare dei supporti strutturali, sotto gli appoggi degli stabilizzatori o sotto i pneumatici, per ripartire il carico su una superficie di appoggio maggiore.
- Quando la lunghezza del braccio o la portata non corrispondono ai valori riportati nelle tabelle, conviene considerare il valore inferiore riportato per il raggio di lavoro o la lunghezza del braccio immediatamente superiore.
- Per lavori su stabilizzatori, TUTTI gli stabilizzatori devono essere completamente estesi e i pneumatici staccati da terra prima di rialzare il braccio o di sollevare carichi.
- I pneumatici devono essere gonfiati alla pressione raccomandata prima di sollevare carichi sopra i pneumatici.

RT600E

GROVE

Load charts • Traglasten • Capacités de levage • Capacidades • Capacità

Working range • Arbeitsbereiche • Diagramme de levage • Gama de trabajo • Area di lavoro



10.1 – 32.0 m



8.8 – 15.5 m



360°

11

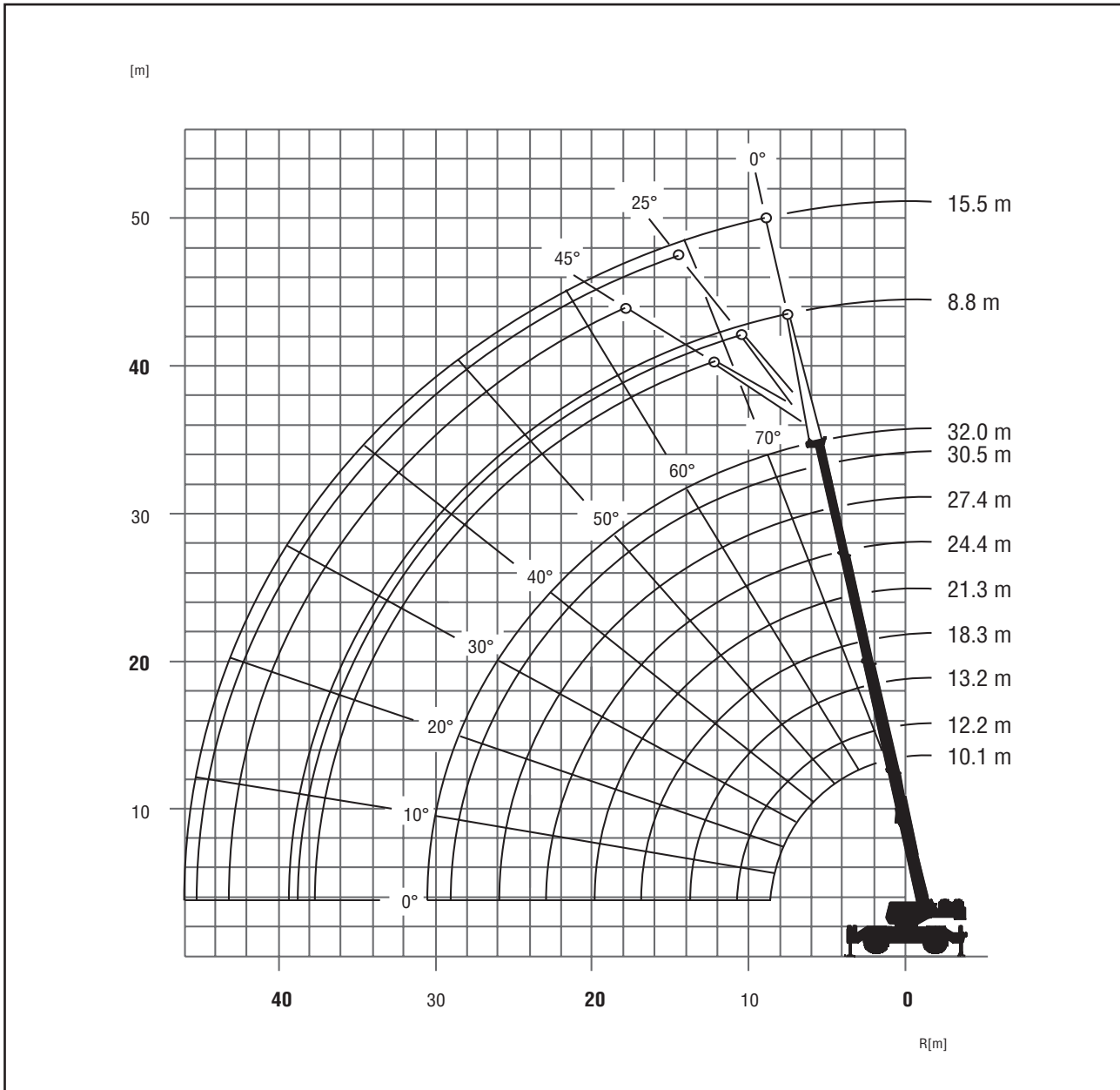

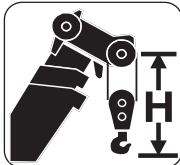
	Hook block • Unterflasche • Crochet-moufle • Gancho • Gancio (t)	H (mm)
	45	2667
35	2667	
7.5 H/B	2515	
—	—	
—	—	

RT600E

Load charts • Traglasten • Capacités de levage • Capacidades • Capacità

Telescopic boom • Teleskopausleger • Flèche principale • Pluma telescópica • Braccio telescopico

12



10.1 – 32.0 m



100%



360°



5,100 kg



RT600A/ISO

m	10.1	12.2	15.2	18.3	21.3	24.4	27.4	30.5	32.0
3.0	45,000	36,525	30,500						
3.5	41,000	36,050	29,475	25,425					
4.0	36,425	34,250	28,375	24,700					
4.5	31,950	31,875	27,325	23,625	20,500				
5.0	28,950	29,175	26,100	22,550	19,650				
6.0	23,425	23,625	23,550	20,375	17,675	15,625	14,225		
7.0	19,600	19,850	20,050	18,875	17,075	14,375	13,125	9,525	8,320
8.0	13,475	16,700	16,925	17,050	16,200	13,125	12,000	9,525	8,320
9.0		14,250	14,500	14,575	14,025	12,075	10,900	9,525	8,320
10.0		9,285	12,475	12,450	12,025	10,775	9,940	9,050	8,320
12.0			8,905	9,055	9,110	8,900	8,615	7,695	7,905
14.0				6,765	6,870	6,860	6,855	6,505	6,595
16.0				5,155	5,240	5,260	5,290	5,320	5,340
18.0					4,040	4,095	4,145	4,195	4,225
20.0						3,210	3,275	3,345	3,380
22.0						2,490	2,595	2,675	2,715
24.0							2,030	2,135	2,180
26.0								1,685	1,740
28.0								1,295	1,360
30.0									1,035

A6-829-1011090



RT650E85%

m	10.1	12.2	15.2	18.3	21.3	24.4	27.4	30.5	32.0
3.0	45,000	36,525	30,500						
3.5	41,000	36,050	29,475	25,425					
4.0	36,425	34,250	28,375	24,700					
4.5	31,950	31,875	27,325	23,625	20,500				
5.0	28,950	29,175	26,100	22,550	19,650				
6.0	23,425	23,625	23,550	20,375	17,675	15,625	14,225		
7.0	19,600	19,850	20,050	18,875	17,075	14,375	13,125	9,525	8,320
8.0	13,475	16,700	16,925	17,050	16,200	13,125	12,000	9,525	8,320
9.0		14,250	14,500	14,625	14,600	12,100	11,050	9,525	8,320
10.0		9,285	12,675	12,800	12,925	11,250	10,250	9,050	8,320
12.0			9,750	9,915	10,075	9,815	8,915	7,695	7,905
14.0				7,465	7,580	7,565	7,560	6,505	7,030
16.0				5,760	5,845	5,860	5,890	5,645	5,945
18.0					4,575	4,625	4,675	4,730	4,760
20.0						3,685	3,750	3,825	3,860
22.0						2,920	3,030	3,110	3,155
24.0							2,430	2,540	2,585
26.0								2,060	2,120
28.0								1,650	1,715
30.0									1,370

A6-829-101042

RT600E

Load charts • Traglasten • Capacités de levage • Capacidades • Capacità

Telescopic boom • Teleskopausleger • Flèche principale • Pluma telescópica • Braccio telescopico



10.1 – 32.0 m



100%



360°



5,100 kg

13



RT640E85%

m	10.1	12.2	15.2	18.3	21.3	24.4	27.4	30.5	32.0
2.2	40,000								
3.0	36,250	33,325	30,475						
3.5	35,250	31,975	28,825	25,425					
4.0	33,775	30,850	27,400	24,700					
4.5	31,625	29,850	26,150	23,625	20,500				
5.0	28,950	27,850	25,225	22,550	19,650				
6.0	23,425	23,525	23,475	20,375	17,675	15,625	14,225		
7.0	19,600	19,850	20,050	18,875	17,075	14,375	13,125	9,525	8,320
8.0	13,475	16,700	16,925	17,050	16,200	13,125	12,000	9,525	8,320
9.0		14,250	14,500	14,625	14,600	12,100	11,050	9,525	8,320
10.0		9,285	12,675	12,800	12,925	11,250	10,250	9,050	8,320
12.0			9,750	9,915	10,075	9,815	8,915	7,695	7,905
14.0				7,465	7,580	7,565	7,560	6,505	7,030
16.0				5,760	5,845	5,860	5,890	5,645	5,945
18.0					4,575	4,625	4,675	4,730	4,760
20.0						3,685	3,750	3,825	3,860
22.0						2,920	3,030	3,110	3,155
24.0							2,430	2,540	2,585
26.0								2,060	2,120
28.0								1,650	1,715
30.0									1,370

A6-829-101028B

RT600E

GROVE®

Load charts • Traglasten • Capacités de levage • Capacidades • Capacità

Telescopic boom • Teleskopausleger • Flèche principale • Pluma telescópica • Braccio telescopico

14

 10.1 – 32.0 m
  50%
  360°
  5,100 kg

		DIN/ISO ♦								RT640E/RT650E	
m	10.1	12.2	15.2	18.3	21.3	24.4	27.4	30.5	32.0		
3.0	36,250	33,325	30,475								
3.5	35,525	31,975	28,825	25,425							
4.0	33,475	30,850	27,400	24,700							
4.5	30,250	28,575	26,150	23,625	20,500						
5.0	25,475	24,275	22,675	21,300	19,650						
6.0	18,450	18,425	17,450	16,550	15,750	15,025	14,225				
7.0	13,675	13,750	13,925	13,375	12,800	12,275	11,800	9,525	8,320		
8.0	10,600	10,700	10,850	11,075	10,650	10,275	9,910	9,525	8,320		
9.0		8,590	8,745	8,945	9,045	8,740	8,445	8,170	8,040		
10.0		7,000	7,185	7,380	7,595	7,520	7,285	7,060	6,955		
12.0			5,040	5,225	5,435	5,455	5,485	5,400	5,325		
14.0				3,820	4,020	4,035	4,060	4,085	4,100		
16.0				2,800	3,025	3,035	3,055	3,080	3,090		
18.0					2,275	2,295	2,310	2,330	2,340		
20.0						1,720	1,735	1,750	1,760		
22.0						1,240	1,275	1,290	1,300		
24.0							890	915	925		
26.0								600	615		

A6-829-101097

 10.1 – 32.0 m
  0%
  360°
  5,100 kg

		DIN/ISO ♦								RT640E/RT650E	
m	10.1	12.2	15.2	18.3	21.3	24.4	27.4	30.5	32.0		
3.0	24,500	23,025	21,100								
3.5	19,850	18,900	17,525	16,325							
4.0	16,500	15,875	14,900	13,975							
4.5	14,000	13,550	12,850	12,125	11,475						
5.0	11,875	11,725	11,200	10,650	10,125						
6.0	8,555	8,605	8,745	8,345	8,065	7,710	7,380				
7.0	6,435	6,480	6,625	6,685	6,550	6,300	6,050	5,810	5,695		
8.0	4,935	5,005	5,150	5,325	5,380	5,215	5,025	4,835	4,745		
9.0		3,925	4,060	4,235	4,430	4,335	4,210	4,060	3,985		
10.0		3,065	3,230	3,400	3,595	3,620	3,525	3,420	3,365		
12.0			2,040	2,205	2,395	2,415	2,440	2,415	2,380		
14.0				1,390	1,580	1,590	1,615	1,640	1,655		
16.0				775	985	995	1,015	1,035	1,050		
18.0					525	545	560	580	590		

A6-829-101098

♦ Also applicable to 85% rating. Auch ausgelegt auf 85 % LMB Einstellung. Les capacités de levage sont valables également à 85%. También aplicable al 85% del momento de vuelco. Le curve di carico sono valide anche per le norm all' 85%.

RT600E

GROVE

Load charts • Traglasten • Capacités de levage • Capacidades • Capacità

Telescopic boom • Teleskopausleger • Flèche principale • Pluma telescópica • Braccio telescopico



10.1 – 21.3 m



23.5 x 25



360°/0°



5,100 kg

15



RT640E/RT650E

m	0 kph					< 4 kph				
	10.1	12.2	15.2	18.3	21.3	10.1	12.2	15.2	18.3	21.3
	360°					0°				
3.0	17,475	17,475				13,675	13,675	8,090		
3.5	15,400	14,900	13,850			13,675	13,675	8,090		
4.0	13,150	12,625	11,850			12,550	11,975	8,090		
4.5	10,775	10,775	10,250	9,645		10,750	10,325	8,090	8,090	6,690
5.0	8,965	8,975	8,965	8,455		9,315	8,990	8,090	7,965	6,690
6.0	6,475	6,485	6,495	6,505	6,425	7,175	6,975	6,670	6,260	6,050
7.0	4,845	4,855	4,870	4,875	4,880	5,670	5,530	5,325	5,000	4,890
8.0	3,700	3,710	3,720	3,730	3,730	4,585	4,450	4,305	4,035	3,990
9.0		2,935	2,950	2,955	2,960		3,620	3,505	3,270	3,270
10.0		2,280	2,295	2,300	2,305		2,980	2,865	2,645	2,685
12.0			1,375	1,380	1,385			1,910	1,705	1,790
14.0									1,030	1,135
16.0									545	640

A6-829-101103

A6-829-101104



RT640E/RT650E

m	0 kph					< 4 kph				
	10.1	12.2	15.2	18.3	21.3	10.1	12.2	15.2	18.3	21.3
	360°					0°				
3.0	17,475	17,475				13,675	13,675	8,090		
3.5	15,400	15,400	14,750			13,675	13,675	8,090		
4.0	13,500	13,500	13,500			13,675	13,675	8,090		
4.5	11,900	11,900	11,900	10,750		13,625	13,625	8,090	8,090	6,690
5.0	10,475	10,475	10,475	10,475		12,450	12,450	8,090	8,090	6,690
6.0	7,650	7,650	7,650	7,650	7,650	10,450	10,450	8,090	8,090	6,690
7.0	5,810	5,810	5,810	5,810	5,810	8,900	8,900	8,090	8,090	6,690
8.0	4,510	4,510	4,510	4,510	4,510	7,650	7,650	7,650	7,650	6,690
9.0		3,630	3,630	3,630	3,630		6,590	6,590	6,590	6,590
10.0		2,890	2,890	2,890	2,890		5,790	5,790	5,790	5,790
12.0			1,850	1,850	1,850			3,410	3,410	3,410
14.0				1,150	1,150				2,630	2,630
16.0				650	650				2,020	2,020
18.0										1,540

A6-829-101085

A6-829-101086

m	0 kph				
	10.1	12.2	15.2	18.3	21.3
	0° (± 6°)				
3.0	21,125	18,500	15,675		
3.5	19,125	18,500	15,675		
4.0	17,225	17,225	15,675		
4.5	15,625	15,625	15,625	12,075	9,750
5.0	14,250	14,250	14,250	12,075	9,750
6.0	12,000	12,000	12,000	12,000	9,750
7.0	10,250	10,250	10,250	10,250	9,750
8.0	8,610	8,610	8,610	8,610	8,610
9.0		6,930	6,930	6,930	6,930
10.0		5,790	5,790	5,790	5,790
12.0			4,180	4,180	4,180
14.0				3,100	3,100
16.0				2,330	2,330
18.0					1,740

A6-829-101084

0° = over front, über Vorderkante, sur avant, par la parte frontale, per la parte frontale

RT600E

GROVE

Load charts • Traglasten • Capacités de levage • Capacidades • Capacità

Swingaway • Klappspitze • Extension treillis • Plumin • Falcone

16



32.0 m



8.8 – 15.5 m



100%



360°



5,100 kg



RT640E/RT650E

		32.0					
		* 8.8			15.5		
m		0°	25°	45°	0°	25°	45°
9.0	4,080						
10.0	4,080						
12.0	4,080		3,585		2,720		
14.0	3,835		3,305	2,565	2,720		
16.0	3,445		3,015	2,515	2,685		
18.0	3,130		2,770	2,420	2,445	1,790	
20.0	2,825		2,535	2,335	2,245	1,670	1,240
22.0	2,610		2,365	2,165	2,070	1,570	1,190
24.0	2,215		2,200	2,010	1,925	1,475	1,150
26.0	1,760		2,015	1,855	1,775	1,395	1,115
28.0	1,375		1,610	1,695	1,650	1,325	1,085
30.0	1,055		1,260		1,490	1,260	1,060
32.0	775		950		1,200	1,205	1,045
34.0	535		680		950	1,155	1,025
36.0					730	990	
38.0					535	755	
40.0						515	

A6-829-10191



85%

		32.0					
		* 8.8			15.5		
m		0°	25°	45°	0°	25°	45°
9.0	4,080						
10.0	4,080						
12.0	4,080		3,625		2,720		
14.0	4,060		3,400	2,565	2,720		
16.0	3,810		3,175	2,515	2,720		
18.0	3,405		2,975	2,420	2,720	1,790	
20.0	3,040		2,800	2,335	2,700	1,670	1,240
22.0	2,720		2,650	2,165	2,470	1,570	1,190
24.0	2,435		2,520	2,010	2,245	1,475	1,150
26.0	2,155		2,395	1,855	2,055	1,395	1,115
28.0	1,750		1,990	1,695	1,890	1,325	1,085
30.0	1,405		1,605		1,745	1,260	1,060
32.0	1,110		1,275		1,525	1,205	1,045
34.0	850		990		1,260	1,155	1,025
36.0	625				1,025	1,115	
38.0					820	1,035	
40.0					635	780	

A6-829-101029

* 8.8 m capacities are also applicable to fixed length offsettable swingaway, 8.8 m Traglasten gelten auch für starre, abwinkelbare Klappspitze, Les capacités de levage sur extension treillis de 8.8 m sont aussi valables pour l'extension treillis inclinable non télescopique, Las capacidades de este plumín de 8.8 m. son también aplicables al plumín de longitud fija no angulable, Le capacità di 8.8 m sono applicabili anche alla lunghezza del jib fisso.

RT600E

GROVE

Load charts • Traglasten • Capacités de levage • Capacidades • Capacità

Swingaway • Klappspitze • Extension treillis • Plumin • Falcone



32.0 m



8.8 – 15.5 m



50%



360°



5,100 kg

17



RT640E/BM750

32.0						
m	* 8.8			15.5		
	0°	25°	45°	0°	25°	45°
9.0	4,080					
10.0	4,080					
12.0	4,080	3,585		2,720		
14.0	3,700	3,305	2,565	2,720		
16.0	2,890	3,015	2,515	2,685		
18.0	2,255	2,655	2,420	2,445	1,790	
20.0	1,740	2,090	2,305	2,075	1,670	1,240
22.0	1,320	1,620	1,795	1,665	1,570	1,190
24.0	965	1,225	1,370	1,320	1,475	1,150
26.0	665	890	1,005	1,025	1,395	1,115
28.0		580	675	770	1,140	1,085
30.0				555	880	1,060
32.0					645	800
34.0						530

A6-829-101099

* Also applicable to 85% rating, Auch ausgelegt auf 85 % LMB Einstellung, Les capacités de levage sont valables également à 85%, También aplicable al 85% del momento de vuelco, Le curve di carico sono valide anche per le norm all' 85%.

* 8.8 m capacities are also applicable to fixed length offsettable swingaway, 8.8 m Traglasten gelten auch für starre, abwinkelbare Klappspitze.

Les capacités de levage sur extension treillis de 8.8 m sont aussi applicables à l'extension treillis inclinable, non télescopique, Las capacidades de este plumín de 8.8 m. son también aplicables al plumín de longitud fija no angularable, Le capacità di 8.8 m sono applicabili anche alla lunghezza del jib fisso.

Weight reductions • Gewichte der Lastaufnahmemittel • Reductions de charge
 Reducciones de peso • Riduzioni di peso

Auxiliary boom nose / Zusatz-Auslegerkopf / Tête de flèche auxiliaire / Cabeza auxiliar / Falconcino ausiliario in testa al braccio	62 kg
Hookblocks / Hakenflaschen / Mouffles / Ganchos / Ganci	
45 tonne 3 sheave / Seilrollen / réas / poleas / carrucole	454 kg
35 tonne 3 sheave / Seilrollen / réas / poleas / carrucole	363 kg
7.5 tonne swivel hook and weight / Hakengeschirr / crochet lesté / gancho y bola / gancio & peso	167 kg
8.8 m Extension / Klappspitze / Prolongacion / Estensione	
Erected / Arbeitsstellung / En position de travail / Montado / Montato	2,001 kg
8.8 m – 15.5 m Extension / Klappspitze / Prolongacion / Estensione	
Erected / In Arbeitsstellung / En position de travail / Montado / Montato (8.8 m)	3,000 kg
Erected / In Arbeitsstellung / En position de travail / Montado / Montato (15.5 m)	4,233 kg

NOTE:
 All load handling devices and boom attachments are considered part of the load and suitable allowances must be made for their combined weights.

HINWEIS:
 Alle Lastaufnahmemittel und jede Zusatzausrüstung des Hauptauslegers werden als Teil der Traglast betrachtet und ihre kombinierten Gewichte müssen beim Feststellen der Nettolast entsprechend berücksichtigt (abgezogen) werden.

REMARQUE:
 Les équipements complémentaires et accessoires de levage sont considérés comme faisant partie de la charge; les réductions de charges de leurs poids combinés doivent être effectuées.

NOTA:
 Todos los aparos de elevacion e implementos de pluma son considerados parte de la carga y deben ser tenidos en cuenta para calcular los pesos a elevar.

NOTA:
 Tutti gli accessori di sollevamento e le opzioni montate sul braccio sono considerati parte del carico e devono essere richieste adeguate autorizzazioni per l'uso dei loro pesi complessive.

RT600E

GROVE

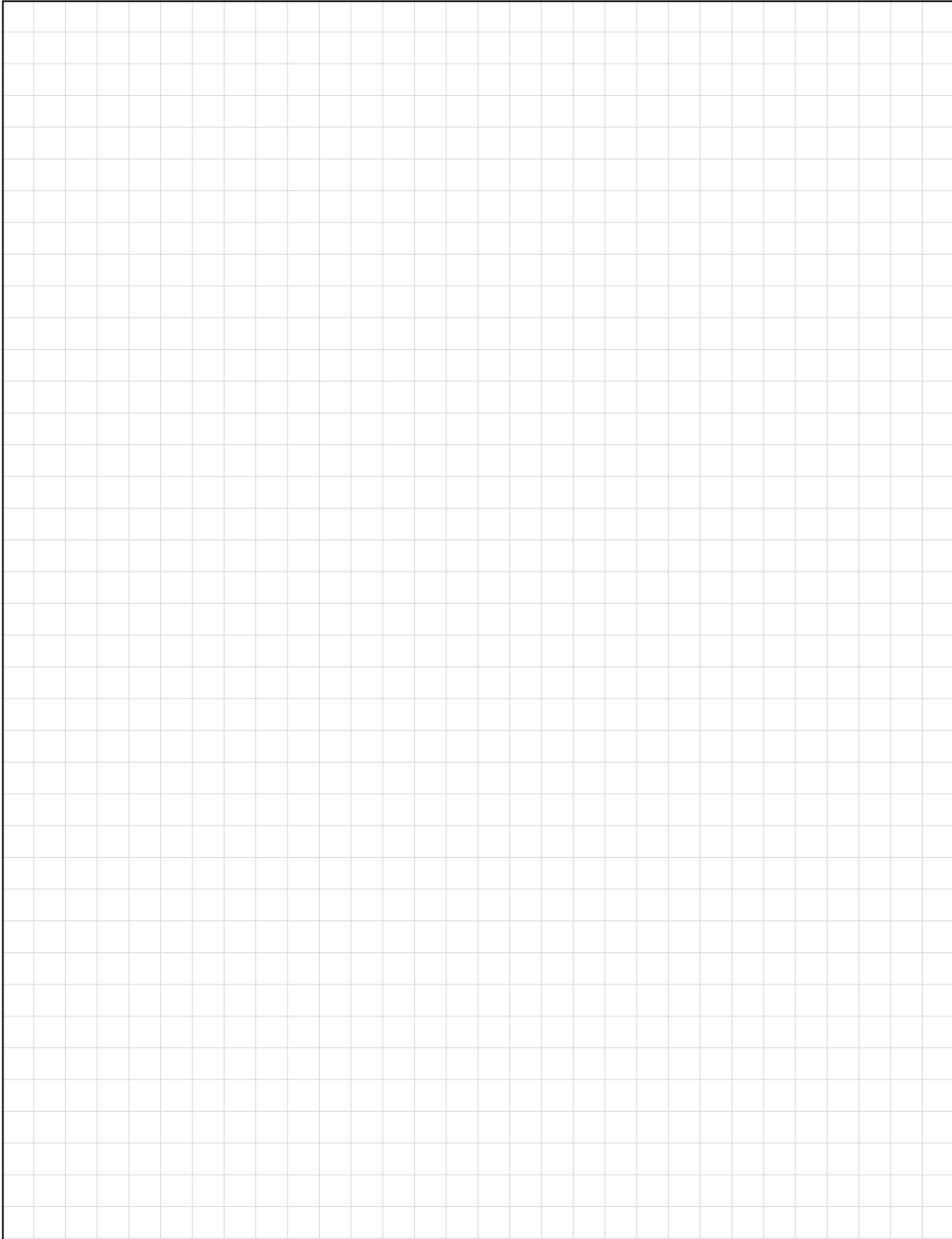

Notes • Hinweise • Notes • Notas • Note

Symbols • Symbolerklärung • Glossaire des symboles • Glosario de simbolos • Glossario dei simboli



Axles
Achsen
Ponts
Ejes
Assali



Crane functions
Kranbewegungen
Mouvements de la grue
Funciones de la grúa
Funzioni della gru



Hookblock / Capacity
Hakenflasche / Traglast
Moufle / Force de levage
Gancho / Capacidad
Gancio / Capacità



Speed
Geschwindigkeit
Vitesse
Velocidad
Velocità



Axle load
Achslast
Charge à l'essieu
Carga por eje
Carico sugli assi



Crane travel
Fahrstellung
Déplacement de la grue
Grúa en traslado
Traslazione gru



Hydraulic system
Hydrauliksystem
Circuit hydraulique
Sistema hidráulico
Impianto idraulico



Suspension
Federung
Suspension
Suspensión
Sospensioni



Boom
Ausleger
Flèche
Pluma
Braccio



Drive/Steer
Antrieb/Lenkung
Direction/Déplacement
Tracción/Dirección
Trazione/Sterzo



Lattice extension
Gitterspitze
Extension treillis
Extensión de celosía
Lunghezza prolunga



Transmission / Gear
Getriebe / Gang
Boîte de vitesses / Rapport
Transmisión / Cambio
Cambio



Boom elevation
Wippwerk
Relevage
Elevacion de pluma
Elevazione braccio



Electrical system
Elektrische Anlage
Circuit électrique
Sistema eléctrico
Impianto elettrico



Lattice extension (luffing)
Auslegerverlängerung (wippbar)
Extension treillis (volée variable)
Extensión de celosía (angulable
hidráulicamente)



Travel speed
Fahrgeschwindigkeit
Vitesse de déplacement
Velocidad de desplazamiento
Velocità di traslazione



Boom telescoping
Teleskopieren
Télescopage de flèche
Telescopaje de pluma
Lunghezza braccio



Engine
Motor
Moteur
Motor
Motore



Luffing Jib
Wippspitzenausleger
Volée variable
Plumín angulable



Tyres
Bereifung
Pneumatiques
Pneumáticos
Pneumatici



Brakes
Bremsen
Freins
Frenos
Freni



Free on wheels
Freistehend
Sur pneus
Sobre neumáticos
Su gomma



Low range
Kleinste Übersetzung
Gamme basse
Marchas cortas
Fuoristrada



Cab
Kabine
Cabine
Cabina
Cabina



Gradeability
Steigfähigkeit
Aptitude en pente
Superacion de pendientes
Pendenza superabile



Outriggers
Abstützung
Calage
Estabilizadores
Stabilizzatori



Carrier frame
Rahman
Châssis porteur
Bastidor
Telaio



Main hoist
Haupthubwerk
Treuil principal
Cabrestante principal
Argano principale



Radius
Ausladung
Portée
Radio
Raggio



Counterweight
Gegengewicht
Contrepoids
Contrapeso
Contrappeso



Auxiliary hoist
Hilfshubwerk
Treuil auxiliaire
Cabrestante auxiliar
Argano secondario



Slewing/Working range
Drehwerk/Arbeitsbereich
Orientation/Rayon d'operation
Giro/Gama de trabajo
Rotazione/Area di lavoro



Manitowoc Crane Group - Americas

Manitowoc, Wisconsin, USA
Tel: +1 920 684 6621
Fax: +1 920 683 6277
Shady Grove, Pennsylvania, USA
Tel: +1 717 597 8121
Fax: +1 717 597 4062

Manitowoc Crane Group - Australia

Sales, Parts, Service
Tel: +61-2-9896-4433
Fax: +61-2-9896-3122

Manitowoc Crane Group - Beijing China

(Sales, Parts & Service)
Tel: +86 (0)10 646-71690 ext 101
Fax: +86 (0)10 646-71691

Manitowoc Crane Group - France

France & Africa
(Sales, Parts & Service)
Tel: +33 (0)1 30 31 31 50
Fax: +33 (0)1 30 38 60 85

Manitowoc Crane Group - Germany

Germany & Central Europe
(Sales, Parts & Service)
Tel: +49 (0)2173 89 09-0
Fax: +49 (0)2173 89 09-30

Manitowoc Crane Group - Italy

Italy & Southern Europe
(Sales, Parts & Service)
Tel: +39 (0)331 49 33 11
Fax: +39 (0)331 49 33 30

Manitowoc Crane Group - Middle East

(Sales)
Tel: +971 (0)4 338 18 61
Fax: +971 (0)4 338 23 43

Manitowoc Crane Group - Netherlands

Netherlands & North West Europe
(Sales, Parts & Service)
Tel: +31 (0)76 578 39 99
Fax: +31 (0)76 578 39 78

Manitowoc Crane Group - Portugal

Portugal & Spain
(Sales, Parts & Service)
Tel: +351 (0)22 969 88 40
Fax: +351 (0)22 969 88 48

Manitowoc Crane Group - Russia

Russia - CIS (Sales)
Tel: +7 495 641 23 59
Fax: +7 495 641 23 58

Manitowoc Crane Group - Shanghai, China

(Sales, Parts & Service)
Tel: +86 (0)21 5489 1515
Fax: +86 (0)21 5489 3565

Manitowoc Crane Group - Singapore

Asia & Pacific excluding China
(Sales, Parts & Service)
Tel: +65 62 64 11 88
Fax: +65 6862-4040/4142

Manitowoc Crane Group - UK

United Kingdom (Sales)
Tel: +44 (0) 1895 430 053
Fax: +44 (0) 1895 459 500
Europe Middle East & Africa (Parts & Service)
Tel: +44 (0) 191 522 2000
Fax: +44 (0) 191 522 2052

Distributed By:



www.manitowoccrane.com

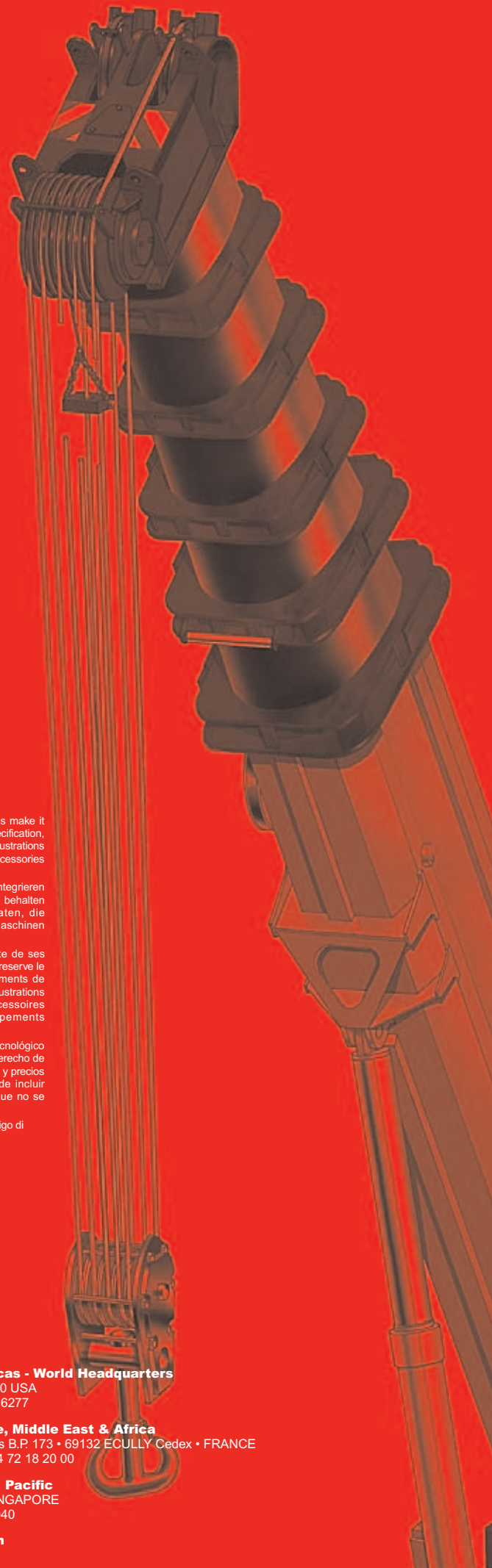

Constant improvement and engineering progress make it necessary that we reserve the right to make specification, equipment, and price changes without notice. Illustrations shown may include optional equipment and accessories and may not include all standard equipment.

Wir verbessern unsere Produkte ständig und integrieren den technischen Fortschritt. Aus diesem Grund behalten wir uns das Recht vor, die technischen Daten, die Ausstattungsdetails und die Preise unserer Maschinen ohne Vorankündigung zu ändern.

Du fait de sa politique d'amélioration constante de ses produits liée au progrès technique, la Société se réserve le droit de procéder sans préavis à des changements de spécifications, d'équipement ou de prix. Les illustrations peuvent comporter des équipements ou accessoires optionnels ou ne pas comporter des équipements standards.

El perfeccionamiento constante y el avance tecnológico hacen necesario que la empresa se reserve el derecho de efectuar cambios en las especificaciones, equipo y precios sin previo aviso. En las ilustraciones se puede incluir equipo y accesorios opcionales y es posible que no se muestre el equipo normal.

Dati e caratteristiche possono variare senza obbligo di preavviso.

Manitowoc Crane Group - Americas - World Headquarters

2044 40th Street • Manitowoc • WI 54220 USA
Tel: +1 920 684 6621 • Fax: +1 920 683 6277

Manitowoc Crane Group - Europe, Middle East & Africa

Potain S.A.S. • 18, rue de Charbonnières B.P. 173 • 69132 ECULLY Cedex • FRANCE
Tel: +33 (0)4 72 18 20 20 • Fax: +33 (0)4 72 18 20 00

Manitowoc Crane Group - Asia & Pacific

4 Kwong Rd. SINGAPORE 628707 • SINGAPORE
Tel: +65 62 64 11 88 • Fax: +65 6862 4040

www.manitowoccrane.com